

Sound Control For Commercial And Residential Buildings

NAIMA
NORTH AMERICAN INSULATION
MANUFACTURERS ASSOCIATION

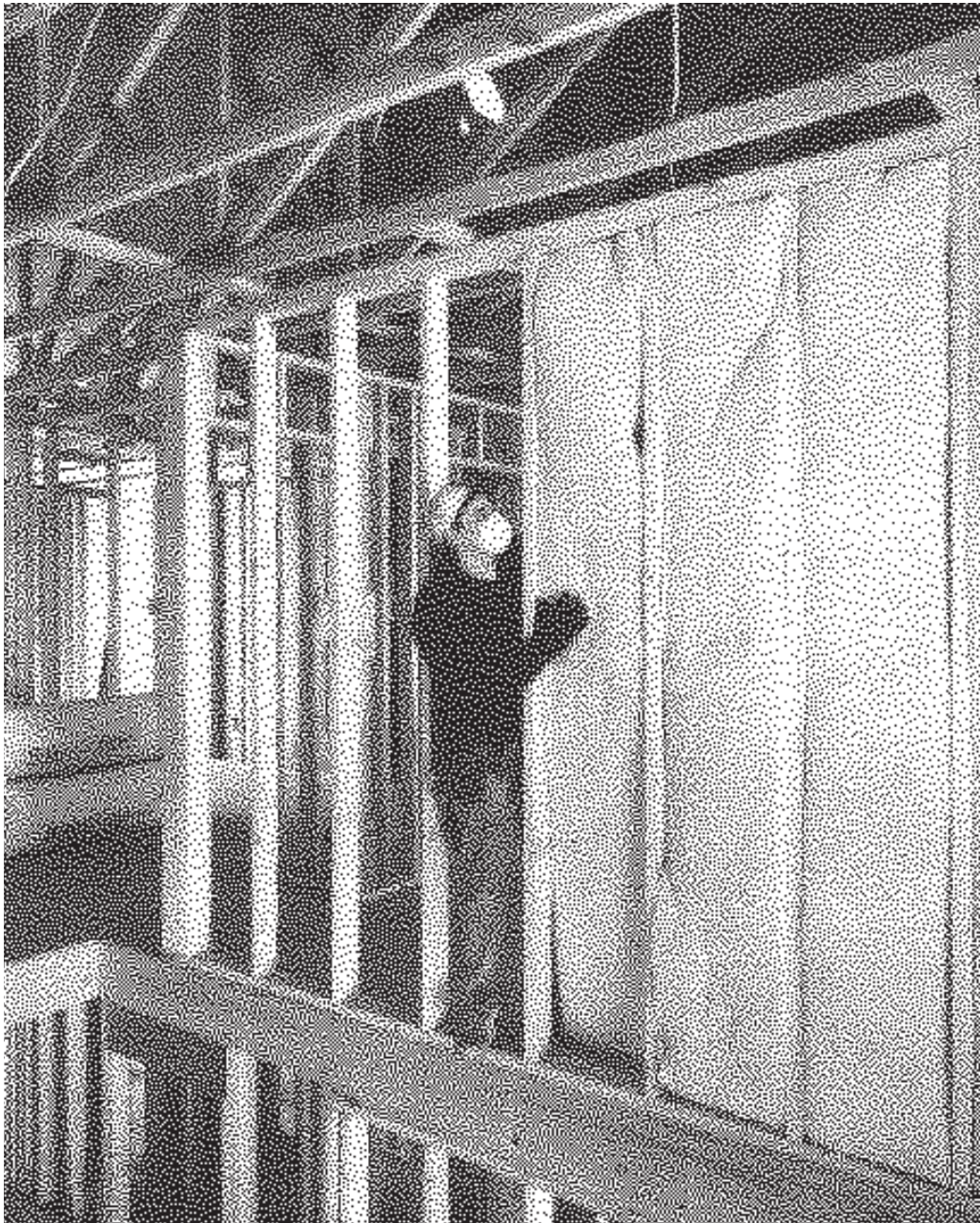

Table Of Contents

Methods Of Sound Control	1
Sound Transmission Class (STC) And Sound Control	1
The Effects Of Insulation Thickness And Density On STC Ratings	2
Controlling Impact Noise	2
Improving Office To Office Sound Reduction	2
Controlling Exterior Sounds	3
Examples Of Ways To Construct Walls And Floors/Ceilings To Achieve Desired STCs	4
Sound Isolation Design Criteria	5
Guide Specification for Fiber Glass Acoustical Insulation	7
Typical Wall Assemblies	
Single Wood Stud Walls	8
Staggered Wood Stud Walls	9
Double Wood Stud Walls	10
Metal Stud Walls	11
Exterior Walls	12
Typical Floor/Ceiling Assemblies	14
Recommended Construction Methods for Controlling Sound	15
Glossary	20
Bibliography	21

How Noise Effects Us

Unwanted sound – or noise – that travels from room to room, from home to home, or office to office, may have a direct impact on people’s notions of privacy, as well as their work efficiency. The noise produced by appliances, piping, heating and air-conditioning systems, phones, radios, TVs and talking are among the major reasons people are dissatisfied with the privacy found in homes or office buildings. Additionally, external noises such as traffic, sirens and extreme weather conditions are equally disturbing. Designing structures to control noise effectively can make homes and offices much more pleasant places in which to live or work.

This Sound Control Guide recommends ways to construct walls and other assemblies using fiber glass insulation to help provide quality noise control.

The North American Insulation Manufacturers Association (NAIMA) developed these recommendations based on the results of numerous acoustical tests using American Society for Testing and Materials (ASTM) methods. However, the recommendations are presented here solely as a guide. NAIMA cannot guarantee, does not represent or warrant, and assumes no responsibility for building design or construction results based on information provided in this booklet because many other factors – including overall design and workmanship – are outside its control.

Methods Of Sound Control

Noise is unwanted sound that is transmitted by vibration through air, walls, floors or ceilings. In a home or office, there are three ways to control sound transmission:

- Increase the mass of partitions
- Break the path of vibration
- Cavity absorption.

Increasing the mass of walls and other structures can present a problem in lightweight construction because the increased weight may not be structurally practical or aesthetically pleasing, not to mention more expensive.

Breaking the vibration path – commonly called discontinuous construction – offers a practical method of reducing sound transmission by as much as 6 to 10 dB.

Cavity absorption, which uses fiber glass insulation to fill the space in walls and floors/ceilings, can further improve performance of discontinuous constructions by 5 to 15 dB.

Sound Transmission Class (STC) And Sound Control

STC ratings are a measure of the effectiveness of a given partition construction in reducing airborne sound transmission. Because of the frequency range covered (125-4000 Hz), STC ratings are best used to evaluate speech privacy for partitions and floors/ceilings separating adjacent offices, rooms in one and two family dwellings, hospital patient rooms, classrooms, dormitories, apartments, courtrooms, small conference rooms, etc. A more extensive

Decibels And Sound Transmission Class

The decibel (dB) is used to express sound intensity or loudness. The more intense a sound, the higher the dB level. The sound transmission class (STC) is a numerical rating of the ability of a wall, floor/ceiling assembly or any other building element, such as a door or window to minimize sound transmission. The higher the STC rating the more the sound is blocked or reduced by the building element (See Table 1). For party walls or walls separating dwelling units, an STC of 50 is considered barely adequate for providing privacy. STCs above 55 are required to provide acceptable privacy.

TABLE 1 – STC Ratings

Sound Transmission Class (STC)	Speech Audibility*	Noise Control Rating
15 to 25	Normal speech easily understood.	Poor
25 to 35	Loud speech easily understood. Normal speech 50% understood.	Marginal
35 to 45	Loud speech 50% understood. Normal speech faintly heard, but not understood.	Good
45 to 55	Loud speech faintly heard, but not understood. Normal speech usually inaudible.	Very Good
55 and up	Loud speech usually inaudible	Excellent

*Given a typical background noise level of 30 dB on the "listening" side

acoustical analysis should be obtained from an acoustical engineer when isolating sound from locations such as music practice rooms, recording studios, large conference rooms and mechanical equipment rooms.

Ratings Based On Lab Tests

STC ratings are based on laboratory tests conducted under ideal construction conditions. Partition manufacturers acknowledge that the field STC of a partition can be up to 15 - 20 points lower than laboratory values depending on the quality of detailing and workmanship. Therefore, the importance of communication between the design team and the construction team cannot be overemphasized.

Fiber Glass Insulation Reduces Sound Transmission

Fiber glass insulation in a partition or floor/ceiling assembly significantly reduces sound transmission. It also reduces sound transmission in roof/ceiling assemblies. It is economical, lightweight and easy to install. Some fiber glass insulation manufacturers sell acoustical or sound control batts for use in partitions. These batts are designed for easier installation in metal and wood stud partitions. They are essentially the same as their corresponding thermal batts, except that they may differ slightly in size and density. A partition with either fiber glass sound control or thermal batts having similar properties would achieve the same STC rating.

Factors That Degrade Performance

The presence of flanking paths, interconnecting ductwork, non-airtight edge joints, inadequate door and window constructions, untreated pipe and conduit penetrations, etc., all degrade the expected performance of a sound rated assembly. When proper attention to construction details are followed, field STC values can be equal to or even greater than laboratory values.

Differences Between Lab Tests Not Unusual

Partitions with STC ratings within 1-2 points (1-2 dB) of the listed criteria would still be acceptable given the anticipated tolerances in repeat tests. In fact, differences between testing labs of 2-5 dB on identical test configurations are not unusual. (Subjectively, the human ear would consider a 1-2 dB change as “nondiscernible” at best, which is insignificant.)

STC Requirements Are From AIA

The STC requirements in Table 3 (pages 5-6) are from the American Institute of Architects (AIA) and assume acceptable background noise levels on both sides of the construction assembly. Normal background noise on the listening side of a partition has the effect of masking transmitted sound that might otherwise be objectionable. In fact, sound transmitted through a partition will be inaudible if its sound level is below the level of the background noise.

The Effects Of Insulation Thickness And Density On STC Ratings

Insulation thickness has a more significant effect on STC ratings than does density. For a typical steel stud wall construction, the first inch of fiber glass insulation can increase the STC value 6 or more points. Each additional inch of fiber glass insulation increases the STC value from one to two points. Conversely, density variations have minimal effect on the STC rating. (See Table 2.)

Controlling Impact Noise

Walls are rated only in terms of their STC value. Floor/ceiling assemblies – because they must also control sounds caused by impacts (such as walking or moving furniture) – are rated in terms of their STC and their impact insulation class, or IIC.

A person walking on a floor creates impact noise that is readily transmitted to the room below. While carpets and pads can cushion impacts and reduce the generation of impact noise, fiber glass insulation can reduce impact and airborne noise transmitted through the floor/ceiling assembly. As with STCs, the higher the IIC value of a floor/ceiling, the better its ability to control impact sound transmission. An acceptable IIC rating is typically 50 or above.

Improving Office To Office Sound Reduction

In offices where the separating partition stops at the ceiling, sound can flank around the partition by traveling through the ceiling. This flanking sound travels up through the ceiling in one office, across the top of the partition and then down through the ceiling in the adjacent office. In many offices this flanking path is significant and degrades the sound isolation between offices. This is particularly true if the STC of the separating partition is greater than 45.

TABLE 2 – STC Values of Equal Thicknesses of
Fiber Glass Insulation

3/8" steel studs; single layer 1/2" gypsum board each side

Material	Thickness	Density	STC
Fiber Glass	2"	0.75 pcf	46
Fiber Glass	2"	1.30 pcf	46
Fiber Glass	2"	3.00 pcf	46

Fiber Glass vs. Cellulose Insulation

Manufacturers of cellulose insulation claim that their insulation, when used in a partition, gives higher STC values than fiber glass insulation. This is not true.

Numerous sound transmission loss tests conducted at independent laboratories have shown that there is no significant difference in STC ratings using either fiber glass or cellulose insulation. The STC ratings of walls using cellulose or fiber glass insulation are within 1 or 2 points of each other:

Metal Framing vs. Wood Framing

Light gage metal framing members are inherently flexible thus allowing the full potential of added cavity insulation to be realized. Single row wood stud framing, on the other hand, provides a high degree of mechanical coupling which can provide a “short-circuit” for sound transmission.

In order to realize the full benefit of cavity insulation in wood framed construction, it is recommended that the gypsum board be attached to either side of the wood framing members using resilient channels. Staggered or double rows of wood studs can also be used to achieve the same benefit. Tests have also shown that there is no significant acoustical difference between 2x4 and 2x6 inch wood studs.

Preventing Ceiling Flanking Sound Transmission

Ceiling flanking sound can be prevented by building partitions from the floor to the roof or floor deck above. However, many times this is not possible because of obstructions such as pipes, conduit and HVAC ducts in the ceiling plenum. In some HVAC designs the ceiling plenum is also used as an air return and partitions can not block the plenum. When this is the case there are two methods to reduce ceiling flanking sound.

Backload Ceiling Panels With Low Density Fiber Glass Insulation

The first method is to back load the ceiling panels with low density fiber glass insulation. The ceiling attenuation class (CAC) can be improved by 6 to 15 points depending on the type of ceiling panel and

the type of grid system. The CAC is the single number rating used to express the sound reduction or attenuation between two rooms sharing a common ceiling and/or plenum (See ASTM standard E 1414). These CAC improvements can be achieved by using unfaced 3 ½ to 4 inch thick batts (R-11 batts). The batts only have to be placed on the back of the ceiling panels on both of sides of the partition a distance of 4 feet back from the partition. It is not necessary to back load the entire ceiling in both offices. Care must be taken not to cover light fixtures with the insulation. The insulation may cause the fixtures to overheat.

Install A “Fuzzwall”

The second method to reduce ceiling flanking sound transmission is to install a fiber glass wall above the separating partition. Such a wall or plenum barrier has been called a “fuzzwall.” (See figure below.)

Fuzzwall Can Improve CAC

Tests conducted by the National Research Council of Canada have shown that a fuzzwall can improve the effective CAC of a ceiling by 10 to 15 points depending on the type of ceiling panel in the ceiling, the type of ceiling grid system and the thickness of the fuzzwall. For air return plenums, openings can be provided in the fuzzwall for air flow. These openings would decrease the STC by approximately 5 points.

Controlling Exterior Sounds

Many residences and commercial buildings are adversely impacted by external sounds or noise. Therefore, it is critical to control both interior and exterior noise. Typical exterior noise sources are automobile and truck traffic, trains, aircraft and our

Basic fuzzwall configuration

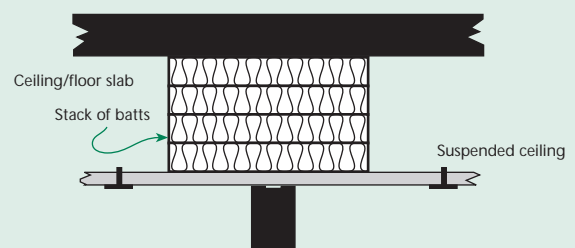

neighbors. The best way to reduce the impact of exterior noise is not to build near these noise sources. When this is not possible then special measures must be taken to reduce their impacts. The shell of a residence or building must be designed to keep out noise.

Residential Construction

In residences, exterior walls should be constructed with resilient furring channels and fiber glass insulation in the stud cavity. If a residence is impacted by overhead aircraft then resilient channels should be used in roof/ceiling assemblies as well as using at least 9 inches of blown-in fiber glass insulation in the attic. The insulation should cover the top of the joists by at least 1 inch.

There should be a minimum number of windows and doors on the side of home facing the exterior noise source. When windows are necessary on this side, they should be sound rated with an STC of at least 40. The same is true for doors facing a noise source.

Recent retrofit programs done on residences near airports to reduce interior noise levels due to aircraft have shown that it is very critical to seal all air (sound) leaks in the building envelope. All fresh air intakes and exhausts must have silencers or mufflers. Most of the residences also had additional insulation installed in the attics to further reduce overhead aircraft noise.

Commercial Construction

In commercial buildings built near a highway or train tracks, the exterior building walls should have at least an STC of 50. Windows and doors should have at least an STC of 40 or 45 depending on the amount of window or door area. The higher the window or door area the higher the STC value. Roof/ceiling systems should also have a minimum STC of 50 if aircraft fly over the building. Higher STC values may be required if aircraft fly close to the building. In this case, an acoustical engineer should be consulted.

Guide Specification

For Fiber Glass Acoustical Insulation

On page 7 is a guide specification that can be used by an architect to specify the acoustical insulation to be used in a wall or floor/ceiling assembly to achieve a desired STC rating. This same specification can be used to specify the acoustical insulation to be used to backload a ceiling system to achieve a desired ceiling STC rating.

Examples Of Ways To Construct Walls And Floors/Ceilings To Achieve Desired STCs

Beginning on page 8 are examples of the most common and typical wall and floor/ceiling assemblies that demonstrate how to improve sound control performance by using fiber glass batts and blankets. Most of the examples shown represent commonly used methods of construction; some variations of these constructions are also illustrated.

STC Ratings

The STC rating indicated for each assembly, in many instances, represents the median of a range of STC values. These median values may or may not be actual test results, but will provide an accurate estimate as to how the STC rating would be increased or decreased with progressive changes in construction. It's possible that an individual insulation manufacturer's results might differ slightly from the median values; however, any such differences would be insignificant. More detailed sound control information can be obtained by contacting an insulation manufacturer.

Fire Ratings

The fire ratings given are based on available test information from NAIMA members and independent testing laboratories. The test method used is ASTM E119. An "NR" indicates that the particular assembly illustrated is not rated.

Table 3 – Sound Isolation Design Criteria

Type of Occupancy	Room(s) Considered (Source)	Adjacent Area(s) (Receiver)	Sound Isolation Requirement (Min.)
Executive areas, doctors' suites – confidential privacy requirements	Office	Adjacent offices General office areas Corridor or lobby Washrooms and toilet areas Exterior of building Kitchen and dining areas Manufacturing areas and mechanical equipment rooms	STC 52 STC 52 STC 52 STC 52 STC 37-60+* STC 52 STC 52+†
Normal office areas – normal privacy requirements	Office	Adjacent offices General office areas Corridor or lobby Washrooms and toilet areas Exterior of building Kitchen and dining areas Manufacturing areas and mechanical equipment rooms	STC 45 STC 45 STC 45 STC 47 STC 37-60+* STC 47 STC 52+†
Any normal occupancy, using conference rooms for group meetings or discussions	Conference rooms	Other conference rooms Adjacent offices General office areas Corridor or lobby Washrooms and toilet areas Exterior of building Kitchen and dining areas Manufacturing areas and mechanical equipment rooms	STC 45 STC 45 STC 45 STC 45 STC 47 STC 37-60+* STC 47 STC 52+†
Normal business offices, drafting areas, banking floors, etc.	Large general office areas	Corridors or lobby Exterior of building Data processing areas Manufacturing areas and mechanical equipment areas Kitchen and dining areas	STC 37 STC 37-60+* STC 42 STC 47+ STC 42
Office in manufacturing, laboratory or test areas requiring normal privacy	Shop and laboratory offices	Adjacent offices Manufacturing, laboratory, or test areas Washrooms and toilet areas Corridor or lobby Exterior of building	STC 42 STC 42+ STC 42 STC 37 STC 37-60+*
Motels and urban hotels (similar to apartments)	Bedrooms	Adjacent bedrooms, separate occupancy Bathrooms, separate occupancy Living rooms, separate occupancy Dining areas Corridor, lobby, or public spaces Mechanical equipment rooms Exterior of building	STC 48+ STC 52+ STC 50+ STC 50+ STC 48+ STC 52+† STC 37-60+*
Apartments, multiple dwelling building	Bedrooms	Adjacent bedrooms, separate occupancy Bathrooms, separate occupancy Bathrooms, same occupancy Living rooms, separate occupancy Living rooms, same occupancy Kitchen areas, separate occupancy Kitchen areas, same occupancy Mechanical equipment rooms Corridors, lobby, public spaces Exterior of building	STC 48-55* STC 52-58* STC 45-52* STC 50-57* STC 42-50* STC 52-58* STC 45-52* STC 58-65* STC 48-55* STC 42-60+†

From The American Institute of Architects; *Architectural Graphic Standards, Seventh Edition*, pp 68 & 69.

* Depends on the nature of the exterior background noise – its level, spectrum shape, and constancy – as well as on the client's budget and on thermal considerations. Use qualified acoustical consultants for analysis of high noise outdoor environments such as airport areas, highways (with heavy truck traffic especially), and industrial facilities.

† Use acoustical consultants for mechanical equipment rooms housing other than air handling equipment – chillers, pumps, compressors, etc. – and for heavy manufacturing areas employing equipment generating noise levels at or above OSHA allowable levels or generating high vibration levels.

Table 3 – Sound Isolation Design Criteria (continued)

Type of Occupancy	Room(s) Considered (Source)	Adjacent Area(s) (Receiver)	Sound Isolation Requirement (Min.)
Apartments, multiple dwelling building	Living rooms	Adjacent living rooms, separate occupancy Bathrooms, separate occupancy Bathrooms, same occupancy Kitchen areas, separate occupancy Mechanical equipment rooms Exterior of building	STC 48-55* STC 50-57* STC 45-52* STC 48-55* STC 58-65* STC 37-60+†
Private, single family residences	Bedrooms (living rooms similar)	Adjacent bedrooms Living rooms Bathrooms, not directly connected with bedroom Kitchen areas Exterior of building	STC 40-48* STC 42-50* STC 45-52* STC 45-52* STC 37-60+†
School buildings	Classrooms	Adjacent classrooms – speech use only Adjacent classrooms – speech and audiovisual use Laboratories Corridor or public areas Kitchen and dining areas Shops Recreational areas Music rooms Mechanical equipment rooms Toilet areas Exterior of building	STC 42 STC 48 STC 48 STC 42 STC 47 STC 52+ STC 52+ STC 52+ STC 55+ STC 47 STC 37-60+†
	Large music or drama areas	Adjacent music or drama rooms Corridor or public areas Practice rooms Shops Recreational areas Laboratories Toilet areas Mechanical equipment rooms Exterior of building	STC 52+ STC 52 STC 52+ STC 57 STC 57 STC 52 STC 52 STC 58-65+ STC 47+†
	Music practice rooms	Adjacent practice rooms Corridors and public areas	STC 52+‡ STC 52+
	Language laboratories	Same as for theaters, concert halls, auditoriums, etc.	
	Counseling offices	Same as for executive offices	
Any occupancy where serious performances are given (requirements may be relaxed for elementary schools or other types of occupancy)	Theaters, concert halls, lecture halls, radio, TV, recording studios	Adjacent similar areas Corridors and public area Recreational areas Mechanical equipment spaces Classrooms Laboratories Shops Toilet areas Exterior of building	Use qualified acoustical consultants to assist in the design of construction details for these critical occupancies†

From The American Institute of Architects; *Architectural Graphic Standards, Seventh Edition*, pp 68 & 69.

* Depends on nighttime, exterior background levels and other factors that affect actual location of building. (Grades I, II, and III are discussed in "A Guide to Airborne, Impact and Structure borne Noise Control in Multifamily Dwellings," HUD-TS-24, 1974, pp. 10-9ff.)

† Discretionary – depends on client's budget, climate, interior planning (closed vs. open), site planning, and other factors. Use qualified acoustical consultants for analysis of high noise outdoor environments such as airport areas, industrial facilities, and highways.

‡ The STC ratings shown are guidelines only. These situations require, typically, double layer construction with resilient connections between layers or, preferably, structurally independent, "room-within-a-room" constructions. The level of continuous background noise, such as that provided by the HVAC system or an electronic masking system, has a significant impact on the quality of construction selected and must be coordinated with the other design parameters.

Part 1 – General

1.01 Summary

- A. Provide glass fiber acoustical insulation as indicated in building plans.

1.02 Materials Provided in Other Sections

These sections are typically cross referenced. Delete sections not included in project manual

- A. Section 09250-Gypsum Board
- B. Section 09260-Gypsum Board Systems
- C. Section 09100-Metal Support Systems

1.03 References

- A. ASTM Standards
 - 1. E 90, Laboratory Measurement of Airborne Sound Transmission Loss of Building Partitions
 - 2. E 413, Rating Sound Insulation
 - 3. E 84, Test Method for Surface Burning Characteristics of Building Materials
 - 4. E 119, Method for Fire Tests of Building Construction Materials
 - 5. E 136, Test Method for Behavior of Materials in a Vertical Tube Furnace at 750°C
 - 6. C 518, Test Method for Steady State Thermal Transmission Properties by Means of the Heat Flow Meter
 - 7. C 665, Specification for Mineral Fiber Blanket Thermal Insulation for Light Frame Construction and Manufactured Housing

1.04 Submittals

Product Data: Submit manufacturer's product literature, samples and installation instructions for specified insulation.

1.05 Delivery, Storage and Handling

- A. Protect insulation from physical damage and from becoming wet, soiled, or covered with ice or snow. Comply with manufacturer's recommendations for

handling, storage and protection during installation.

- B. Label insulation packages to include material name, production date and/or product code

Delete paragraph below if sections 01600 or 01620 are not included in project manual.

- [C. Deliver and store materials under provision of section (01600) (01620).]

1.06 Limitations

- A. Do not use unfaced insulation in exposed applications where there is potential for skin contact and irritation.

Part 2 – Products

2.01 Manufacturer

Name of insulation manufacturer

2.02 Material

Specify name of fiber glass insulation.

- A. Type: Unfaced glass fiber acoustical insulation complying with ASTM C 665.
- B. Combustion Characteristics: Passes ASTM E 136 test.
- C. Surface Burning Characteristics:
 - 1. Maximum flame spread: 25.
 - 2. Maximum smoke developed: 50 When tested in accordance with ASTM E 84.*
- D. Fire Resistance Ratings: Passes ASTM E 119 test.
- E. Sound Transmission Class of the assembly: STC _____
- F. Size of the insulation
Thickness__ Width__ Length__

2.03 Gypsum Board

- A. Refer to Section (09250) (09260) for detailed specifications.

Select appropriate construction

- [B. Type: 1/2" thick, type "x" gypsum panels.]

- [C. Type: 5/8" thick, type "x" gypsum panels.]

2.04 Metal Framing

- A. Refer to Section (09250) (09260)

for detailed specifications.

Select appropriate construction

- [B. Type: 2-1/2" steel stud.]

- [C. Type: 3-5/8" steel stud.]

Part 3 – Execution

3.01 Inspection and Preparation

- A. Examine substrates and conditions under which insulation work is to be performed. A satisfactory substrate is one that complies with requirements of the section in which substrate and related work is specified.
- B. Obtain installer's written report listing conditions detrimental to performance of work in this section. Do not proceed with installation until unsatisfactory conditions have been corrected.
- C. Clean substrates of substances harmful to insulation.

3.02 Installation - General

- A. Comply with manufacturer's instructions for particular conditions of installation in each case.
- B. Batts may be friction-fit in place until the interior finish is applied. Install batts to fill entire stud cavity. If stud cavity is less than 96" in height, cut lengths to friction-fit against floor and ceiling tracks. Walls with penetrations require that insulation be carefully cut to fit around outlets, junction boxes and other irregularities.
- C. Where insulation must extend higher than 8 feet, supplementary support can be provided to hold product in place until the interior finish is applied.

* This standard is used solely to measure and describe the properties of products in response to heat and flame under controlled conditions. These numerical ratings are not intended to reflect hazards presented by this or any other material under actual fire conditions. Values are reported to the nearest fire rating.

Typical Wall Assemblies

Single Wood Stud Walls

STC-38

(Figure 1)

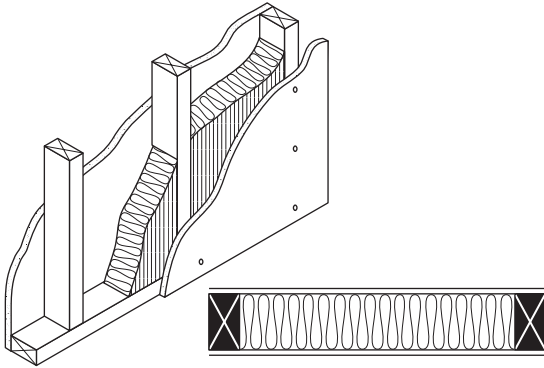

Single 2x4 wood studs, 16" o.c., single layer 1/2" gypsum board each side, one thickness (3 1/2" - 4") fiber glass batt insulation.

Fire rating - NR.

Single Finish

Variation	Construction	Finish*	STC	Fire Rating
1A	1/2" GB <i>No insulation</i>	Single	35	1/2 hr.
1B	5/8" Type X GB <i>No insulation</i>	Single	34	1 hr.
1C	5/8" Type X GB (3 1/2"-4") fiber glass batt	Single	38 (est.)	1 hr.
1D	Studs 24" o.c. 5/8" Type X GB (3 1/2"-4") fiber glass batt	Single	40 (est.)	1 hr.

STC-40

(Figure 2)

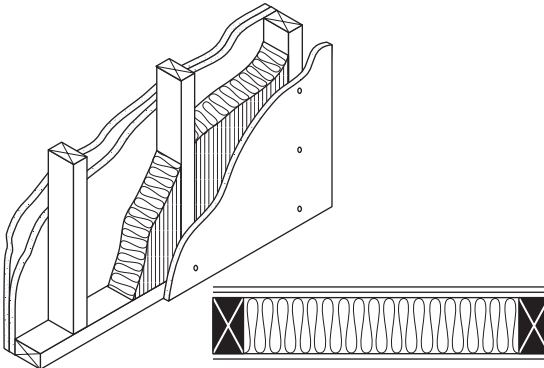

Single 2x4 wood studs, 16" o.c., single layer 1/2" gypsum board one side, double layer other side, one thickness (3 1/2" - 4") fiber glass batt insulation.

Fire rating - NR

Unbalanced Finish

Variation	Construction	Finish*	STC	Fire Rating
2A	1/2" GB <i>No insulation</i>	Unbal.	38	NR
2B	5/8" Type X GB <i>No insulation</i>	Unbal.	38 (est.)	1 hr. (est.)
2C	5/8" Type X GB (3 1/2"-4") fiber glass batt	Unbal.	41	1 hr. (est.)

STC-45

(Figure 3)

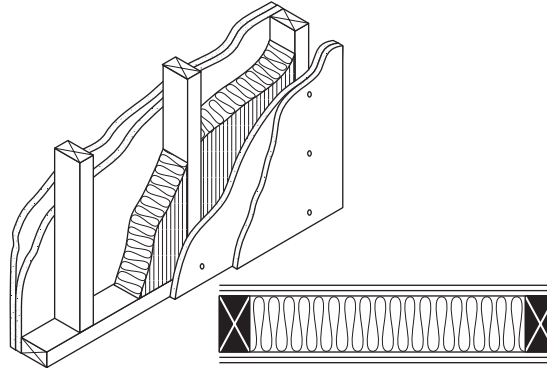

Single 2x4 wood studs, 16" o.c., double layer 1/2" Type X gypsum board each side, one thickness (3 1/2" - 4") fiber glass batt insulation.

Fire rating - 1 hr.

Balanced Finish

Variation	Construction	Finish*	STC	Fire Rating
3A	1/2" Type X GB <i>No insulation</i>	Balanced	39	1 hr. (est.)
3B	Studs 24" o.c. 1/2" Type X GB <i>No insulation</i>	Balanced	39	1 hr. (est.)

STC-50

(Figure 4)

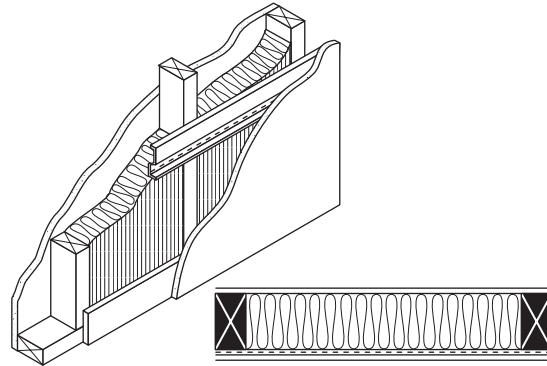

Single 2x4 wood studs, 16" o.c., with resilient channel, single layer 5/8" Type X gypsum each side, one thickness (3 1/2" - 4") fiber glass batt insulation.

Fire rating - 1 hr.

Single Finish

Variation	Construction	Finish*	STC	Fire Rating
4A	1/2" GB <i>No insulation</i>	Single	39	NR
4B	5/8" Type X GB <i>No insulation</i>	Single	40	1 hr.
4C	1/2" GB (3 1/2"-4") fiber glass batt	Single	47	NR
4D	Studs 24" o.c. 5/8" Type X GB (3 1/2"-4") fiber glass batt	Single	52	1 hr.

* *Single* - one wall finish each side

Unbalanced - one wall finish one side, two wall finishes other side

Balanced - two wall finishes each side.

Partitions with STC ratings within 1-2 points of the listed criteria are acceptable given the anticipated tolerances in repeat tests. In fact, discrepancies between testing labs of 1-2 dB on identical configurations are not unusual. (Subjectively, the human ear would consider a 1-2 dB change as "non-discernible" at best, which is insignificant.)

Typical Wall Assemblies (continued)

STC-52

(Figure 5)

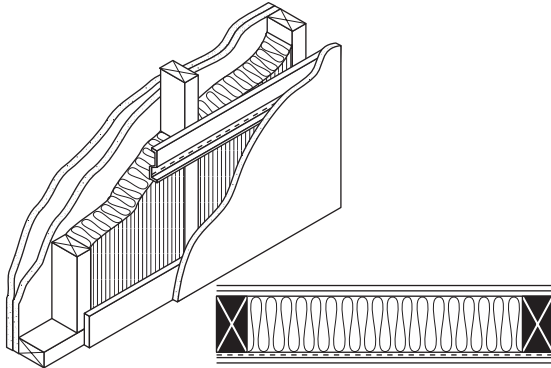

Single 2x4 wood studs, 16" o.c., with resilient channel, single layer 1/2" gypsum board one side, double layer other side, one thickness (3 1/2"- 4") fiber glass batt insulation.

Fire rating - NR Unbalanced Finish

Variation	Construction	Finish*	STC	Fire Rating
5A	1/2" GB <i>No insulation</i>	Unbal.	44	NR
5B	5/8" Type X GB <i>No insulation</i>	Unbal.	48 (est.)	1 hr.
5C	Studs 24" o.c. 1/2" GB (3 1/2"-4") fiber glass batt	Unbal.	55	NR

STC-55 (est.)

(Figure 6)

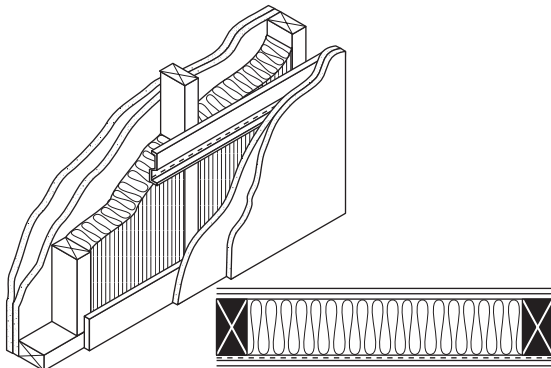

Single 2x4 wood studs, 16" o.c., with resilient channel, double layer 1/2" Type X gypsum board each side, one thickness (3 1/2"- 4") fiber glass batt insulation.

Fire rating - 1 hr. Balanced Finish

Variation	Construction	Finish*	STC	Fire Rating
6A	1/2" Type X GB <i>No insulation</i>	Balanced	52	1 hr
6B	Studs 24" o.c. 1/2" Type X GB (3 1/2"-4") fiber glass batt	Balanced	57	1 hr. (est.)

Staggered Wood Stud Walls

STC-50

(Figure 7)

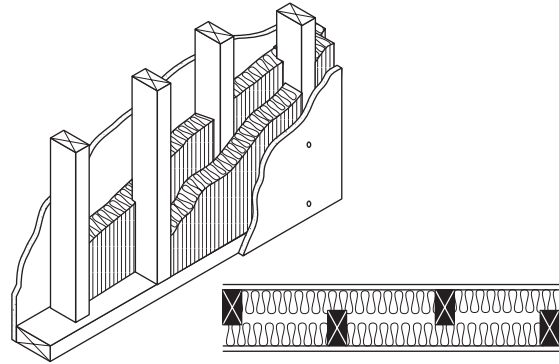

Staggered 2x4 wood studs, 16" o.c., 2x6 top and bottom plates, single layer 1/2" Type X gypsum board each side, two thicknesses (2 1/2") fiber glass batt insulation.

Fire rating - 1 hr. Single Finish

Variation	Construction	Finish*	STC	Fire Rating
7A	1/2" GB <i>No insulation</i>	Single	39	NR
7B	4 5/8" Type X GB <i>No insulation</i>	Single	3	1 hr.
7C	1/2" GB <i>One thickness of (3 1/2"-4") fiber glass batt</i>	Single	49	NR
7D	5/8" Type X GB <i>Two thicknesses of (2 1/2") fiber glass batt</i>	Single	51 (est.)	1 hr.
7E	Studs 24" o.c. 1/2" Type X GB <i>One thickness of (3 1/2"-4") fiber glass batt</i>	Single	52	1 hr. (est.)

STC-53

(Figure 8)

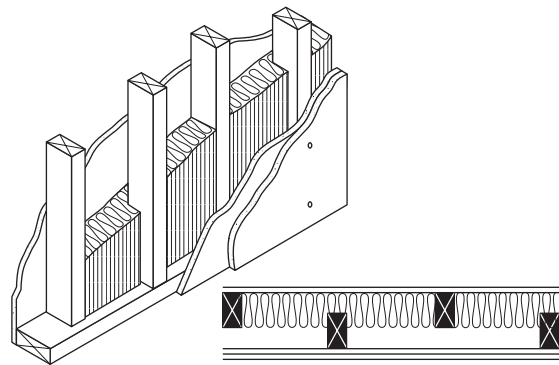

Staggered 2x4 wood studs, 24" o.c., 2x6 top and bottom plates single layer 1/2" gypsum board one side, double layer other side, one thickness (3 1/2"- 4") fiber glass batt insulation.

Fire rating - NR Unbalanced Finish

Variation	Construction	Finish*	STC	Fire Rating
8A	1/2" GB <i>No insulation</i>	Unbal.	47	NR
8B	Studs 16" o.c. 1/2" GB (3 1/2"-4") fiber glass batt	Unbal.	51	NR

* *Single* – one wall finish each side

Unbalanced – one wall finish one side, two wall finishes other side

Balanced – two wall finishes each side.

Partitions with STC ratings within 1-2 points of the listed criteria are acceptable given the anticipated tolerances in repeat tests. In fact, discrepancies between testing labs of 1-2 dB on identical configurations are not unusual. (Subjectively, the human ear would consider a 1-2 dB change as "non-discernible" at best, which is insignificant).

Typical Wall Assemblies (continued)

STC-55

(Figure 9)

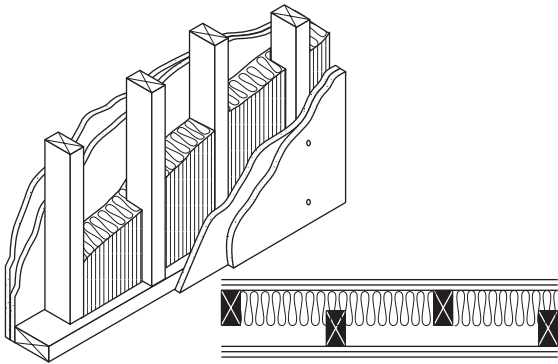

Staggered 2x4 wood studs, 24" o.c., double layer 1/2" Type X gypsum board each side, one thickness (3 1/2"- 4") fiber glass batt insulation.

Fire rating - 1 hr. (est.)

Balanced Finish

Variation	Construction	Finish*	STC	Fire Rating
9A	1/2" Type X GB <i>No insulation</i>	Balanced	52	1 hr. (est.)
9B	Studs 16" o.c. 1/2" Type X GB (3 1/2"-4") fiber glass batt	Balanced	53	1 hr. (est.)
9C	Studs 16" o.c. 3/8" Type X GB (3 1/2"-4") fiber glass batt	Balanced	53	2 hr.

Double Wood Stud Walls

STC-57 (est.)

(Figure 10)

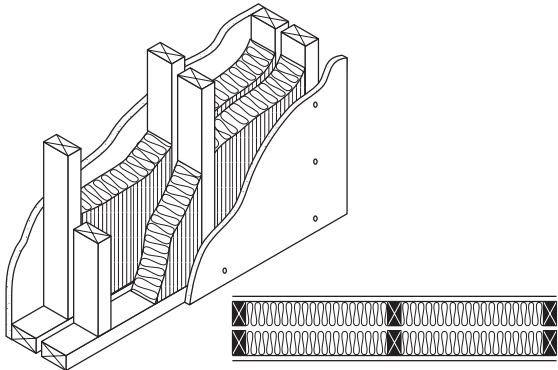

Double 2x4 wood studs, 16" o.c., single layer 1/2" Type X gypsum board one side, two thicknesses (3 1/2"- 4") fiber glass batt insulation.

Fire rating - 1 hr.

Single Finish

Variation	Construction	Finish*	STC	Fire Rating
10A	1/2" GB, <i>No insulation</i>	Single	46	NR
10B	3/8" Type X GB <i>No insulation</i>	Single	45	1 hr.
10C	1/2" GB. <i>One thickness of (3 1/2"-4") fiber glass batt</i>	Single	56	NR
10D	3/8" Type X GB <i>One thickness of (3 1/2"-4") fiber glass batt</i>	Single	56	1 hr.
10E	Studs 24" o.c., 1/2" GB <i>One thickness of (3 1/2"-4") fiber glass batt</i>	Single	56	NR
10F	Studs 24" o.c., 1/2" GB Two thicknesses of (3 1/2"-4") fiber glass batt	Single	60	NR

* *Single* - one wall finish each side

Unbalanced - one wall finish one side, two wall finishes other side

Balanced - two wall finishes each side.

Partitions with STC ratings within 1-2 points of the listed criteria are acceptable given the anticipated tolerances in repeat tests. In fact, discrepancies between testing labs of 1-2 dB on identical configurations are not unusual. (Subjectively, the human ear would consider a 1-2 dB change as "non-discernible" at best, which is insignificant.)

STC-60

(Figure 11)

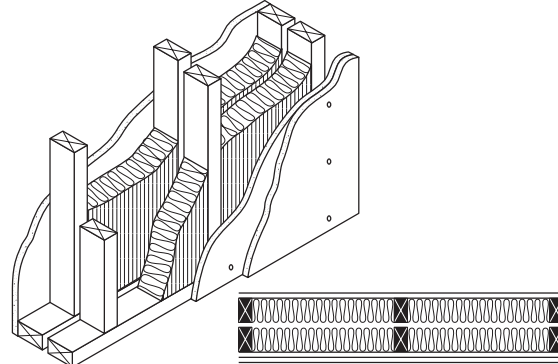

Double 2x4 wood studs, 16" o.c., single layer 1/2" Type X gypsum board one side, double layer other side, two thicknesses (3 1/2"- 4") fiber glass batt insulation.

Fire rating - 1 hr.

Unbalanced Finish

Variation	Construction	Finish*	STC	Fire Rating
11A	1/2" GB <i>No insulation</i>	Unbal.	46	NR
11B	3/8" Type X GB <i>No insulation</i>	Unbal.	52	1 hr.
11C	1/2" GB <i>One thickness of (3 1/2"-4") fiber glass batt</i>	Unbal.	56	NR
11D	Studs 24" o.c. 1/2" GB Two thicknesses of (3 1/2"-4") fiber glass batt	Unbal.	64	NR

STC-63

(Figure 12)

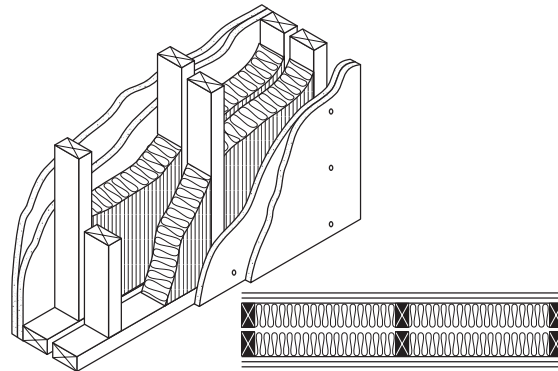

Double 2x4 wood studs, 16" o.c., double layer 1/2" Type X gypsum board each side, two thicknesses (3 1/2"- 4") fiber glass batt insulation.

Fire rating - 1 hr.

Balanced Finish

Variation	Construction	Finish*	STC	Fire Rating
12A	1/2" Type X GB <i>No insulation</i>	Balanced	54	1 hr.
12B	1/2" Type X GB <i>One thickness of (3 1/2"-4") fiber glass batt</i>	Balanced	64	1 hr.
12C	Studs 24" o.c. 1/2" GB <i>One thickness of (3 1/2"-4") fiber glass batt</i>	Balanced	65	NR

Typical Wall Assemblies (continued)

Metal Stud Walls

STC-45

(Figure 13)

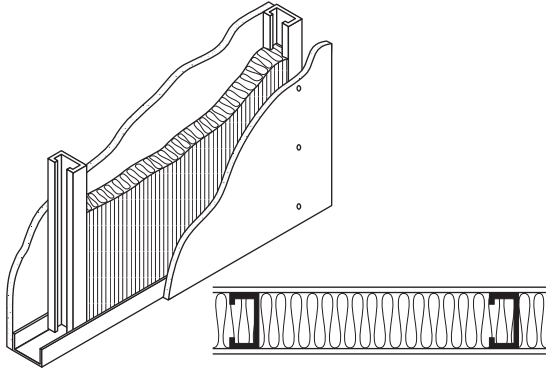

2½" metal studs (25 gauge), 24" o.c., single layer ½" gypsum board each side, one thickness (2½"-2¾") fiber glass batt insulation.

Fire rating - NR			Single Finish	
Variation	Construction	Finish*	STC	Fire Rating
13A	½" GB <i>No insulation</i>	Single	36	NR
13B	⅝" Type X GB <i>No insulation</i>	Single	39	1 hr.
13C	⅝" Type X GB (2½"-2¾") fiber glass batt	Single	47	1 hr.

STC-50

(Figure 14)

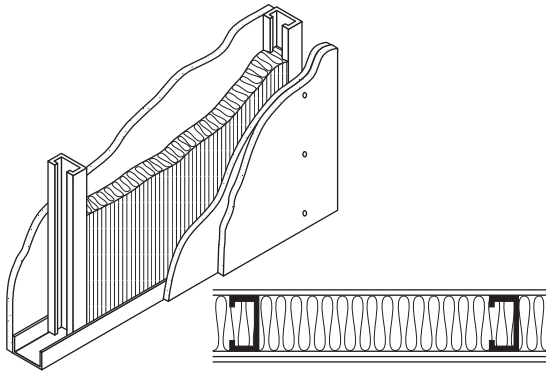

2½" metal studs (25 gauge), 24" o.c., single layer ½" gypsum board each side, double layer other side, one thickness (2½"-2¾") fiber glass batt insulation.

Fire rating - NR			Unbalanced Finish	
Variation	Construction	Finish*	STC	Fire Rating
14A	½" GB <i>No insulation</i>	Unbal.	39	NR
14B	⅝" Type X GB <i>No insulation</i>	Unbal.	44	1 hr.
14C	⅝" Type X GB (2½"-2¾") fiber glass batt.	Unbal.	52	1 hr.

STC-54

(Figure 15)

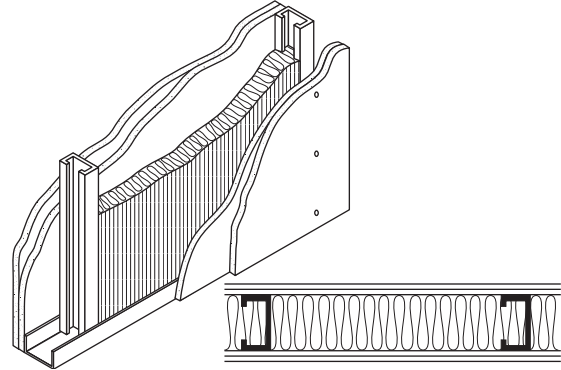

2½" metal studs (25 gauge), 24" o.c., double layer ½" gypsum board each side, one thickness (2½"-2¾") fiber glass batt insulation.

Fire rating - NR			Balanced Finish	
Variation	Construction	Finish*	STC	Fire Rating
15A	½" Type X GB <i>No insulation</i>	Balanced	45	2 hr.
15B	⅝" Type X GB <i>No insulation</i>	Balanced	48	2 hr.
15C	⅝" Type X GB (2½"-2¾") fiber glass batt	Balanced	57	2 hr.

STC-47

(Figure 16)

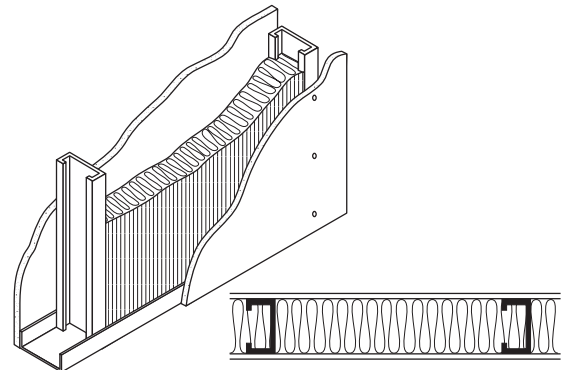

3½" metal studs (25 gauge), 24" o.c., single layer ½" Type X gypsum board each side, one thickness (3½"-4") fiber glass batt insulation.

Fire rating - 1 hr.			Single Finish	
Variation	Construction	Finish*	STC	Fire Rating
16A	½" GB <i>No insulation</i>	Single	39	NR
16B	⅝" Type X GB <i>No insulation</i>	Single	39	1 hr.
16C	⅝" Type X GB (3½"-4") fiber glass batt.	Single	50	1 hr.

* *Single* – one wall finish each side

Unbalanced – one wall finish one side, two wall finishes other side

Balanced – two wall finishes each side.

Partitions with STC ratings within 1-2 points of the listed criteria are acceptable given the anticipated tolerances in repeat tests. In fact, discrepancies between testing labs of 1-2 dB on identical configurations are not unusual. (Subjectively, the human ear would consider a 1-2 dB change as "non-discernible" at best, which is insignificant).

Typical Wall Assemblies (continued)

STC-52

(Figure 17)

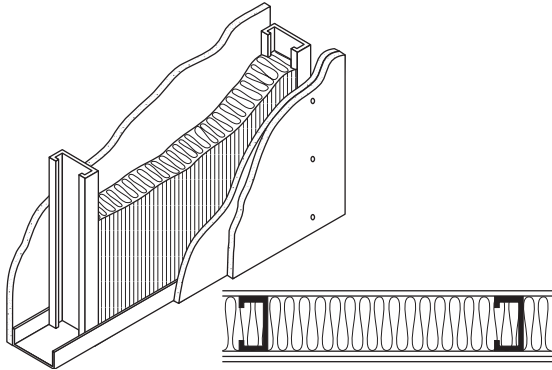

3/8" metal studs (25 gauge), 24" o.c., single layer 1/2" gypsum board one side, double layer other side, one thickness (3/8"-4") fiber glass batt insulation.

Fire rating - NR

Unbalanced Finish

Variation	Construction	Finish*	STC	Fire Rating
17A	1/2" GB <i>No insulation</i>	Unbal.	42	NR
17B	3/8" Type X GB <i>No insulation</i>	Unbal.	47	1 hr.
17C	5/8" Type X GB (3/8"-4") fiber glass batt	Unbal.	55	1 hr.

STC-56

(Figure 18)

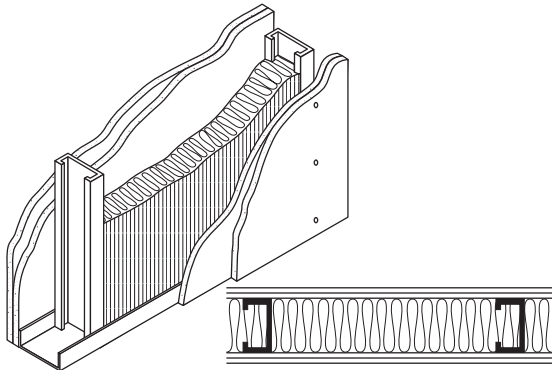

3/8" metal studs (25 gauge), 24" o.c., double layer 1/2" Type X gypsum board each side, one thickness (3/8"-4") fiber glass batt insulation.

Fire rating - 2 hr

Balanced Finish

Variation	Construction	Finish*	STC	Fire Rating
18A	1/2" Type X GB <i>No insulation</i>	Balanced	50	2 hr.
18B	3/8" Type X GB <i>No insulation</i>	Balanced	52	2 hr.
18C	5/8" Type X GB (3/8"-4") fiber glass batt	Balanced	58	2 hr.

Exterior Walls

STC-47

(Figure 19)

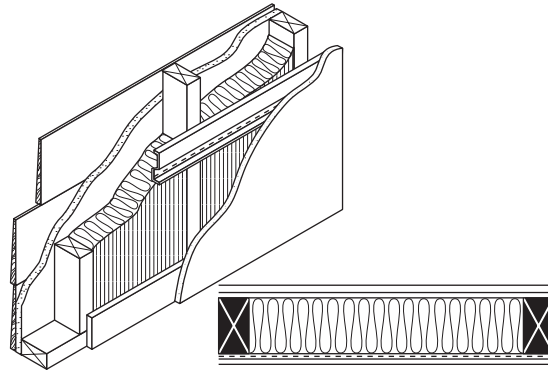

Exterior frame wall, 5/8"x10" redwood siding 1/2" sheathing, 2x4 studs, 16" o.c., resilient channel, 1/2" gypsum board, one thickness (3/8"-4") fiber glass batt insulation.

Fire Rating - NR

Variation	Construction	STC	Fire Rating
19A	<i>No insulation</i>	43	NR
19B	<i>No resilient channel</i> (3/8"-4") fiber glass batt	39	NR
19C	<i>No resilient channel</i> <i>No insulation</i>	37	NR

STC-57

(Figure 20)

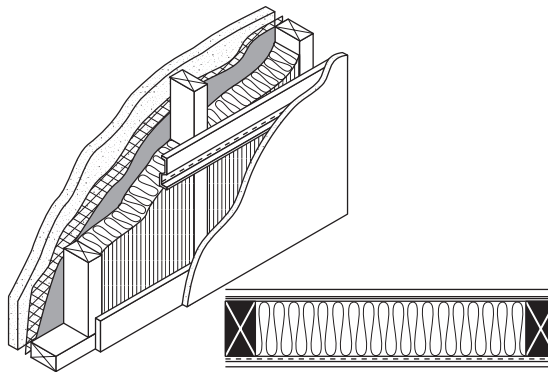

Exterior 7/8" stucco, 1" woven mesh and no.15 felt paper and, 2x4 studs, 16" o.c., resilient channel, 1/2" gypsum board, one thickness (3/8"-4") fiber glass batt insulation.

Fire Rating - NR

Variation	Construction	STC	Fire Rating
20A	<i>No insulation</i>	49	NR
20B	<i>No resilient channel</i> (3/8"-4") fiber glass batt	46	NR

* *Single* - one wall finish each side

Unbalanced - one wall finish one side, two wall finishes other side

Balanced - two wall finishes each side.

Partitions with STC ratings within 1-2 points of the listed criteria are acceptable given the anticipated tolerances in repeat tests. In fact, discrepancies between testing labs of 1-2 dB on identical configurations are not unusual. (Subjectively, the human ear would consider a 1-2 dB change as "non-discernible" at best, which is insignificant.)

Typical Wall Assemblies (continued)

STC-58

(Figure 21)

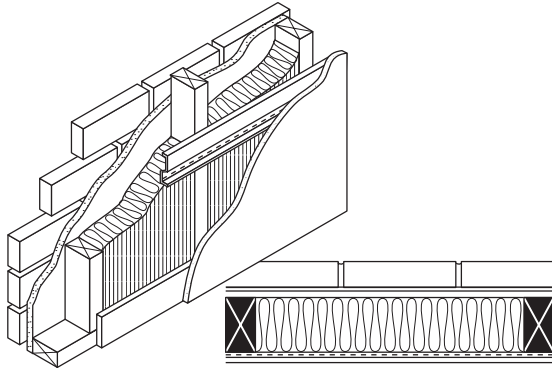

Exterior brick veneer, 1/2" air space, 3/4" insulative sheathing, 2x4 studs, 16" o.c., resilient channel, 1/2" gypsum board, one thickness (3 1/2" - 4") fiber glass batt insulation.

Fire Rating - NR

Variation	Construction	STC	Fire Rating
21A	<i>No insulation</i>	54	NR
21B	<i>No resilient channel</i> (3 1/2"-4") fiber glass batt	56	NR

STC -39

(Figure 23)

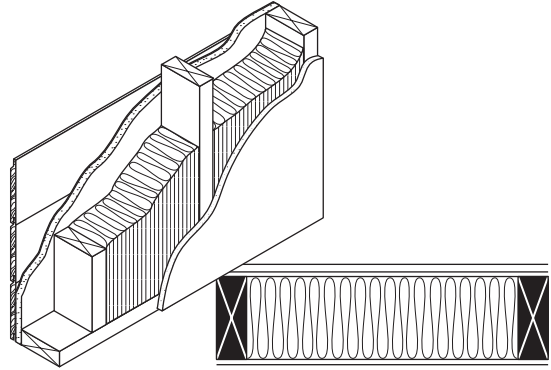

Exterior 1/16"x10" hardwood lap siding, 1/16" foil faced foam sheathing, 2x6 studs, 16" o.c., 1/2" gypsum board, one thickness (5 1/2") fiber glass batt insulation.

Fire Rating - NR

Variation	Construction	STC	Fire Rating
23A	<i>No insulation</i>	38	NR
23B	<i>With resilient channel</i> (5 1/2") fiber glass batt	45	NR

STC-40

(Figure 22)

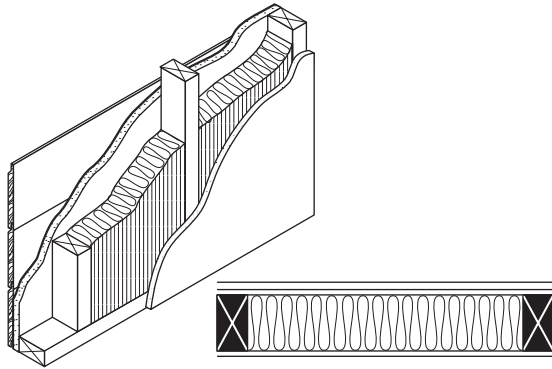

Exterior 1/16"x10" hardwood lap siding 1/16" foil faced foam sheathing, 2x4 studs, 16" o.c., 1/2" gypsum board, one thickness (3 1/2" - 4") fiber glass batt insulation.

Fire Rating - NR

Variation	Construction	Finish*	STC	Fire Rating
22A	<i>No insulation</i>		36	NR

* *Single* – one wall finish each side

Unbalanced – one wall finish one side, two wall finishes other side

Balanced – two wall finishes each side.

Partitions with STC ratings within 1-2 points of the listed criteria are acceptable given the anticipated tolerances in repeat tests. In fact, discrepancies between testing labs of 1-2 dB on identical configurations are not unusual. (Subjectively, the human ear would consider a 1-2 dB change as "non-discernible" at best, which is insignificant).

Typical Floor/Ceiling Assemblies

STC-53 IIC-73

(Figure 25)

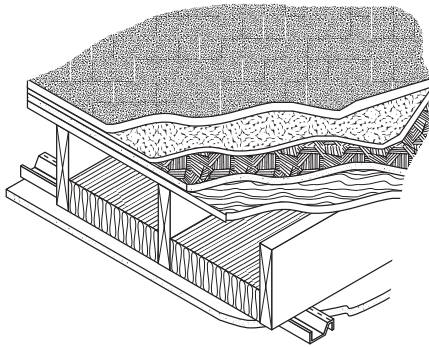

Wood Floor

Carpet and pad, 3/8" particle board, 3/8" plywood subfloor, 2x10 joists 16" o.c., one thickness (3 1/2" - 4") fiber glass batt insulation, resilient channel, 1/2" Type X gypsum board.

Fire Rating - 1 hr.

Variation	Construction	IIC	STC	Fire Rating
25A	No resilient channel No insulation	60	42	NR
25B	1/2" plywood floor 3/8" plywood subfloor	72	50	NR
25C	Vinyl floor instead of carpet and pad	49	50	NR

STC-56 IIC-71

(Figure 27)

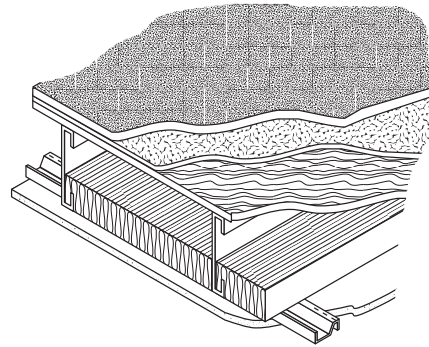

Steel Joist Floor

Carpet and pad, 3/4" T&G plywood subwood subfloor, steel joists (7/8", 18 ga.) 24" o.c., one thickness (3 1/2" - 4") fiber glass batt insulation, resilient channel, 3/8" gypsum board.

Fire Rating - NR

Variation	Construction	IIC	STC	Fire Rating
27A	No resilient channel No insulation	57	43	NR

STC-58 IIC-74

(Figure 26)

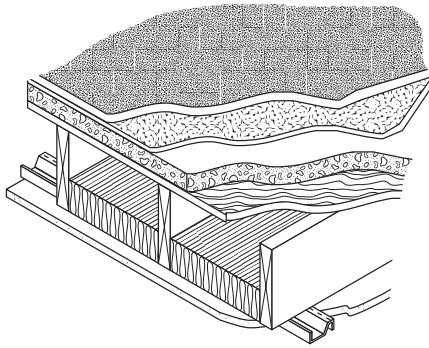

Concrete Floor

Carpet and pad, 1 1/2" lightweight concrete floor, 3/8" plywood subfloor, 2x10 joists 16" o.c., one thickness (3 1/2" - 4") fiber glass batt insulation, resilient channel, 1/2" Type X gypsum board.

Fire Rating - 1 hr. est.

Variation	Construction	IIC	STC	Fire Rating
26A	No resilient channel No insulation	59	47	NR
26B	2x8 joists, 1 1/2" lightweight concrete floor	74	53	NR
26C	2x8 joists, Vinyl floor instead of carpet and pad	47	50	NR

STC-51 IIC-78

(Figure 28)

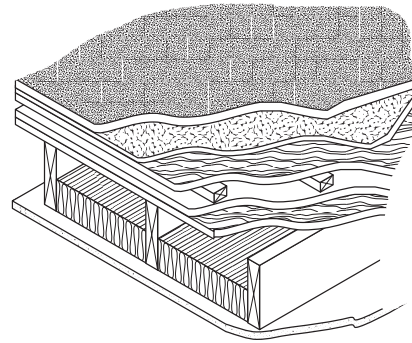

Plywood Floor

Carpet and pad, 3/8" plywood floor, 2" x 3" furring, 1/2" sound deadening board, 1/2" plywood subfloor, 2x8 wood joists, one thickness (3 1/2" - 4") fiber glass batt insulation, resilient channel, 3/8" Type X gypsum board.

Fire Rating - NR

Variation	Construction	IIC	STC	Fire Rating
28A	With vinyl floor instead of carpet and pad	49	52	NR

* Single - one wall finish each side

Unbalanced - one wall finish one side, two wall finishes other side

Balanced - two wall finishes each side.

Partitions with STC ratings within 1-2 points of the listed criteria are acceptable given the anticipated tolerances in repeat tests. In fact, discrepancies between testing labs of 1-2 dB on identical configurations are not unusual. (Subjectively, the human ear would consider a 1-2 dB change as "non-discernible" at best, which is insignificant.)

Recommended Construction Methods for Controlling Sound

Doors

- Stagger doors across hallways and use gasketing.
- Avoid sliding doors in areas where sound control is desired.
- Use doors of solid wood or insulated cores wherever privacy is an important consideration; hollow-core doors will not be as effective.

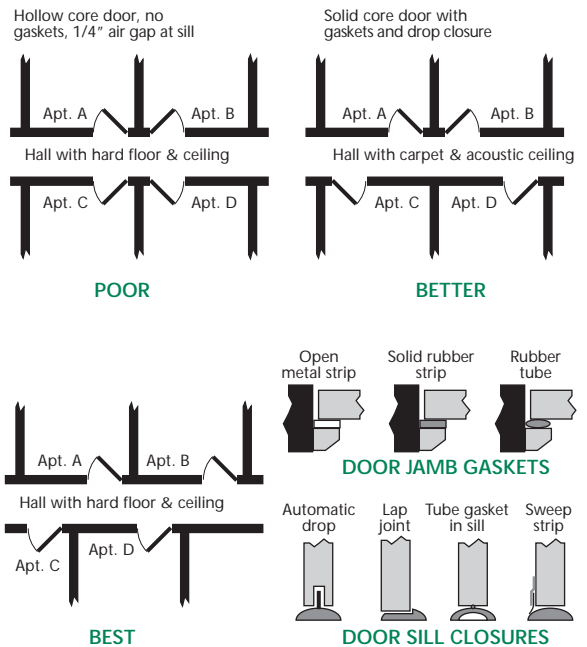

Windows

- Minimize the size of windows facing noisy areas.
- Separate windows to reduce cross-talk.
- Arrange casement windows so sound is not reflected into adjoining units.
- Make sure movable windows close tightly and are weather-stripped.
- Use thick glass, insulating glass or storm windows to help reduce sound transmission through windows.

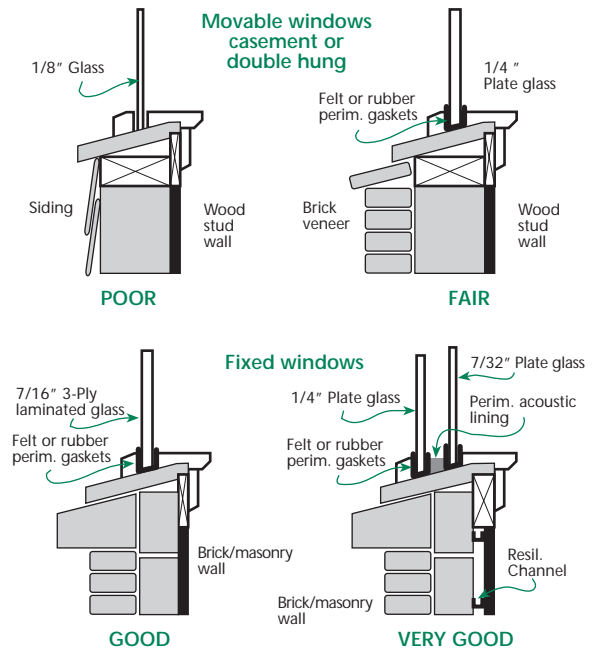

Wiring

- Wire each apartment as a unit; avoid penetration of walls or floors between apartments.
- Caulk holes (made by wiring) that penetrate connecting structures; use elastic, non-hardening caulk or dry packing.
- Connect vibrating equipment with flexible wiring.

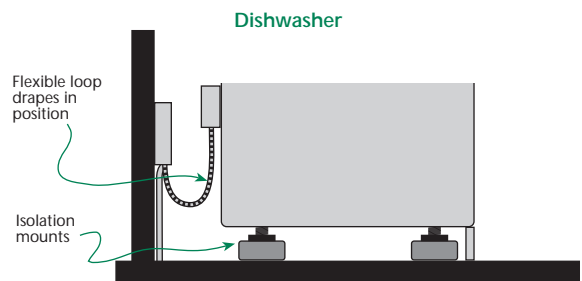

Electrical Outlets

- Cut holes neatly to reduce leaks.
- Make sure outlets are airtight by using elastic, non-hardening caulk before installing the plates.
- Don't install electrical outlets back to back.

Switch or electrical outlet. Use quiet type light switches throughout apts., particularly in party walls.

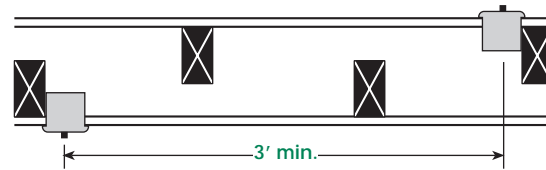

DO

Discourage placement of TV sets against party walls by providing TV antenna, outlets in non-party walls. Avoid recessed back-to-back mounting of electrical outlets.

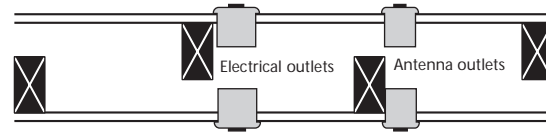

DON'T

Ceiling Fixtures

- Surface mount any ceiling fixtures on resiliently mounted gypsum ceilings.
- Make sure openings around boxes are sealed air tight.
- Don't use recessed or "hi-hat" type fixtures without boxing in the fixture.

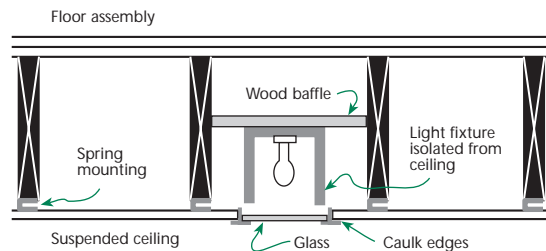

DO

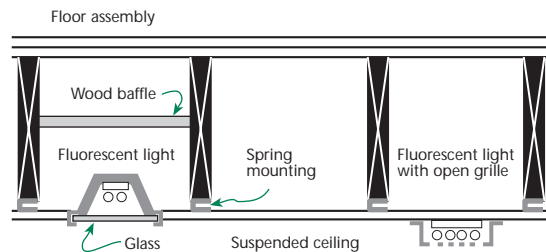

DO

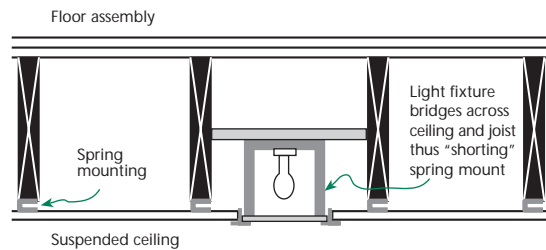

DON'T

Electrical Distribution Panels

- Install these panels on interior walls within apartments and never on corridor or party walls.

Plumbing

- Design pipe runs with swing arms so expansion and contraction can occur without binding, thus eliminating noise.
- Isolate piping from structures with resilient pads and sleeves, then seal for air tightness.
- Develop a well-planned layout to minimize the noise of flowing water.
- Use oversized pipes and reduced pressures to slow the speed of flowing water and reduce noise.
- Provide air chambers to eliminate water hammer due to abrupt stopping of flowing water.
- Use quiet-action water closets that are isolated from the structure on a floating floor.
- Caulk all openings made in walls, floors and framing for supply and drain lines.

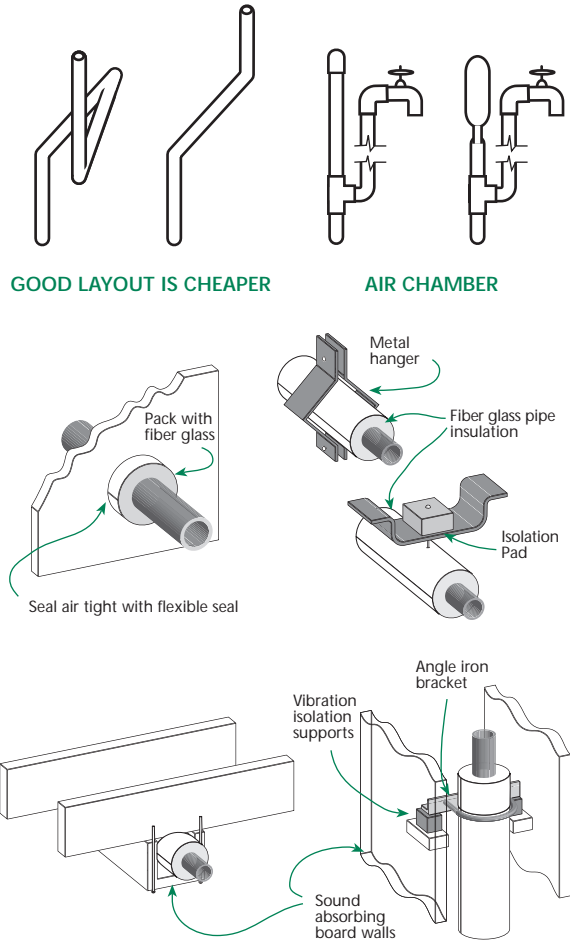

Appliances and Air Conditioners

- Select quiet, high-quality appliances.
- Use adequately-sized water piping and valves to minimize whistling.
- Select quiet air conditioners with balanced fans and motors.
- Select quiet external ballast on fluorescent fixtures.

Phones and Other Noise-Making Equipment

- Install phones, doorbells, intercoms, etc., on interior walls only – never on party walls or corridor walls.

Insulated Duct Systems

- Use performed fiber glass ducts or fiber glass duct liners to quiet fan noise and the sounds of air rushing through the ducts.

See chart below for an acoustical comparison between uninsulated (bare) ducts and various types of insulated ducts. For more information on insulated duct systems contact NAIMA and request a copy of publication number: *AH121, A Guide to Insulated Duct Systems*.

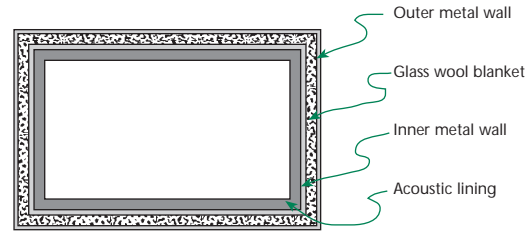

Description	Sound Frequency					
	125	250	500	1000	2000	4000
Bare Sheet Metal ¹ No perceived noise reduction.	.1	.1	.1	.1	.1	.1
Wrapped Sheet Metal ¹ No perceived noise reduction.	.2	.2	.2	.2	.2	.2
Lined Sheet Metal (1" thick) ² Significant perceived noise reduction.	.3	.7	1.9	5.3	4.8	2.3
Fiber Glass Air Duct (1" thick) ³ Very significant reduction. Perceived noise reduced to less than 1/3 original level.	.4	1.4	3.3	3.9	5.0	3.7

1. Version 1.1, 1978 ASHRAE Transactions, Vol 84, Part 1, p.122
 2. ASHRAE HVAC Systems & Applications Handbook, 1987, Ch. 52
 3. Noise Control Manual, O.C. 6th Edition, 1986

Medicine Cabinets

- Separate or surface mount medicine cabinets or install mirrors on party walls with medicine cabinets on interior partitions.

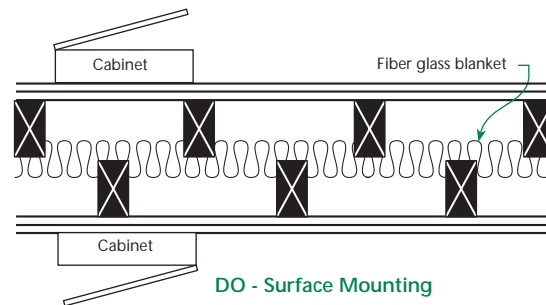
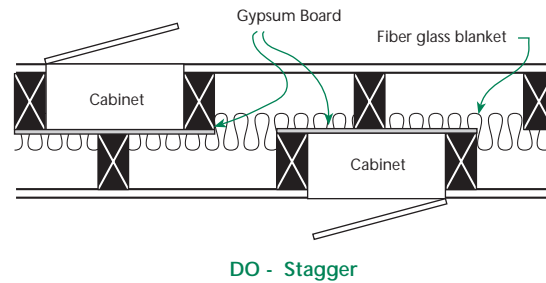

Avoid recessed, back-to-back mounting of cabinets in party walls

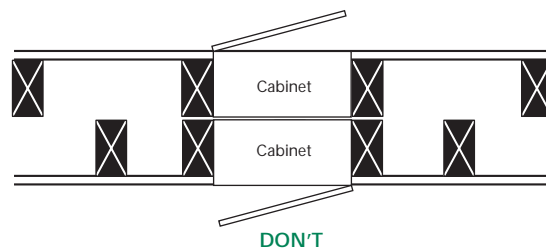

Equipment Noise

- Locate heating and cooling equipment far from bedrooms.
- Inquire about equipment noise levels before buying and insist on quiet units.
- Isolate equipment in rooms with a door to the outside or use a gasketed, solid-core door when access is from building interior
- Mount equipment so as to keep vibrations from entering surrounding structures.
- Construct partitions separating living units from equipment rooms with an STC of 50 or better

Wall Bases

- Install plates on sill sealers; run wall finish to floor where possible and caulk airtight on both sides.

Cracks in Floor

- Seal all cracks in the subfloor airtight with caulking.

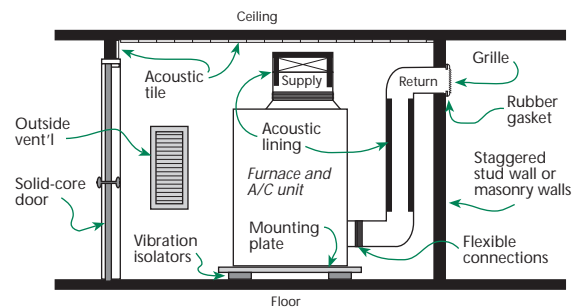
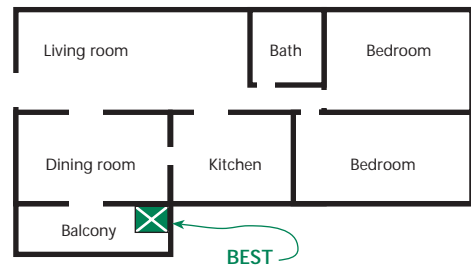
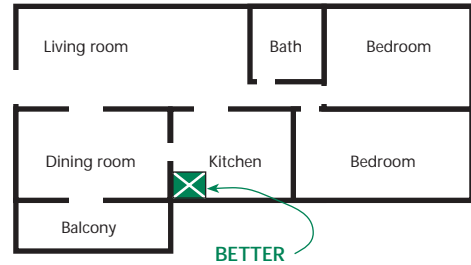
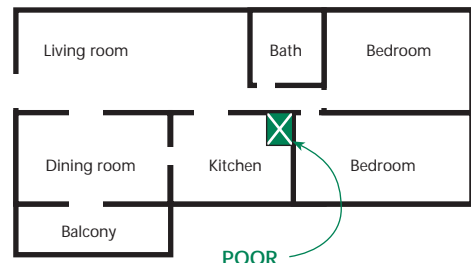

Glossary

Absorption The ability of a material to absorb rather than reflect sound waves striking it by converting sound energy to heat energy within the material.

Acoustics The science of sound, including its production, transmission and effects.

Airborne Sound Sound, produced by vibrating sources that radiate sound directly into the air, which is transmitted through air as a medium rather than through solids or the structure of the building.

Background Noise Normal sound always present in a space created either by outdoor sounds such as street traffic or indoor sounds such as ventilating noise, appliances, etc.

Decibel Logarithmic unit expressing the ratio between a given sound being measured and a reference point.

Discontinuous Construction Any of several construction methods, such as the use of staggered studs, double walls, or resilient mounting of surfaces, used to break the continuous paths through which sound may be transmitted.

Flanking Paths A wall or floor/ceiling construction that permits sound to be transmitted along its surface; or any opening which permits the direct transmission of sound through the air.

Frequency The number of complete cycles of a vibration performed in one second, measured in cycles per second (cps) and expressed in Hertz (Hz).

Hertz (Hz) A unit of frequency of a periodic process equal to one cycle per second.

Impact Insulation Class (IIC) A single number rating developed by the Federal Housing Administration to estimate the impact sound isolation performance of floor/ceiling systems.

Noise Unwanted sound.

Noise Reduction Reducing the level of unwanted sound by any of several means of acoustical treatment.

Noise Reduction Coefficient A single number index of the noise reducing efficiency of acoustical materials. It is found by averaging the sound absorption coefficients at 250, 500, 1000 and 2000 cps.

Sound A vibration in any elastic medium within the frequency range capable of producing the sensation of hearing.

Sound Attenuation Reduction of the energy or intensity of sound.

Sound Transmission The passage of sound through a material construction or other medium. *Airborne Sound Transmission:* Sound transmitted when a surface is set into vibration by the alternating air pressures of incident sound waves.

Sound Transmission Class (STC) A single number rating for evaluating efficiency of constructions in isolating airborne sound transmission. The higher the STC rating the more efficient the construction.

Transmission Loss The decrease or attenuation in sound energy (expressed in decibels) of airborne sound as it passes through a building construction.

Bibliography

CertainTeed Corp., *Fire Resistance and Sound Control Guide*. Available from CertainTeed Corp. P.O. Box 860, Valley Forge, Pennsylvania 19482.

Knauf Fiber Glass, *The Sound Solution*. Available from Knauf Fiber Glass, One Knauf Drive, Shelbyville, Indiana 46176.

Loney, W., *Effect of Cavity Absorption on the Sound Transmission Loss of Steel Stud Gypsum Wallboard Partitions*, *The Journal of Acoustical Society of America*, Vol. 49, No.2, 1971.

Loney, W., *Effect of Cavity Absorption and Multiple Layers of Wallboard on the Sound Transmission Loss of Steel Stud Gypsum Wallboard Partitions*, *The Journal of Acoustical Society of America*, Vol. 53, No. 6, 1973.

Halliwell, R. E. and Quirt, J. D., *Controlling Interoffice Sound Transmission Through a Suspended Ceiling*, *The Journal of Acoustical Society of America*, Vol. 90, Sept. 1991.

NAHB Research Foundation, Inc., *Insulation Manual/Home, Apartments - Second Edition*. Available from NAIMA, 44 Canal Center Plaza, Suite 310, Alexandria, VA 22314.

Office of Noise Control, California Department of Health Services, *Catalog of STC and IIC Ratings for Wall and Floor/Ceiling Assemblies*, 2151 Berkeley Way, Berkeley, California 94704.

Owens Corning, *Noise Control Design in Residential Construction*. 1980. Available from Owens Corning, One Owens Corning Parkway, Toledo, OH 43659.

Johns Manville, *Sound Control*. Available from Johns Manville, PO Box 5108, Denver, Colorado 80217.

The American Institute of Architects, *Architectural Graphic Standards, Seventh Edition*, "Sound Isolation Design Criteria Table." Ramsey/Sleeper, Reprinted by permission of John Wiley & Sons, Inc.

U.S. Department of Commerce, *NBC Handbook 119, Quieting: A Practical Guide to Noise Control*, July 1976. Available from Superintendent of Documents, U.S. Government Printing Office, Washington, DC 20002.

U.S. Department of Commerce, *National Bureau of Standards, Acoustical and Thermal Performance of Exterior Residential Walls, Doors and Windows*. NBS Building Sciences 77, November 1975. Available from Superintendent of Documents, U.S. Government Printing Office, Washington, DC 20002.

ABOUT NAIMA

NAIMA is a trade association of North American manufacturers of fiber glass, rock wool, and slag wool insulation products. NAIMA's role is to promote energy efficiency and environmental preservation through the use of fiber glass, rock wool, and slag wool insulation products and to encourage safe production and use of these insulation products.

NAIMA Building Insulation Committee:

CertainTeed Corporation, 800/233-8990
750 E. Swedesford Road, Valley Forge, PA 19482

Johns Manville, 800/654-3103
P.O. Box 5108, Denver, CO 80217

Knauf Fiber Glass, 800/825-4434
One Knauf Drive, Shelbyville, IN 46176

Owens Corning, 800/GET-PINK
One Owens Corning Parkway, Toledo, OH 43659

For additional information contact to:

NAIMA
44 Canal Center Plaza
Suite 310
Alexandria, Virginia 22314
Tel: 703/684-0084
Fax: 703/684-0427
E-mail: insulation@naima.org
Website: <http://www.naima.org>

